

Economy Lifting Beams



BLACKTHORN, INC.

• 800-836-6113 FAX 937-836-9395

Model 16 Adjustable Spreader/Lifting Beam

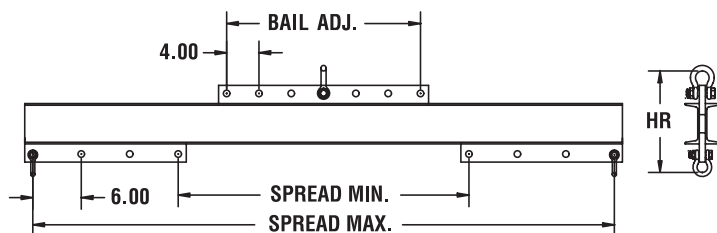
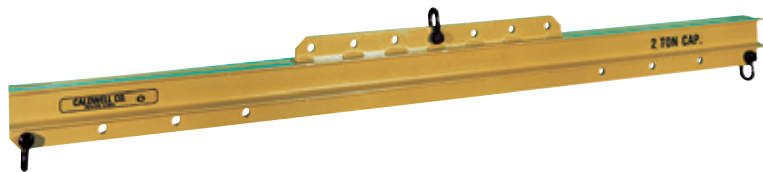

PRODUCT FEATURES:

- ¥ Use as 2, 3 or 4 point lifting or spreader beam.
- ¥ Converts to spreader beam with addition of top rigging.
- ¥ Has adjustable lifting points.
- ¥ Can handle both wide and unbalanced loads.
- ¥ Low headroom design.
- ¥ Shackles included.
- ¥ Designed and manufactured to ASME B30.20.

PRODUCT OPTIONS:

- ¥ Pair of swivel hooks - Code S
- ¥ Chain top rigging - Code C
- ¥ Cross beams (one or two) specify spread(s) - Consult factory



MODEL NO.	RATED CAP. (tons)	SPREAD (in.)		BAIL ADJ. (in.)	HEADROOM (in.)	BOLT TYPE ANCHOR SHACKLE (tons)		OPTIONAL SWIVEL HOOK (tons)	WGT. (lbs.)
		MAX	MIN			TOP	BOTTOM		
16-1/4-4	1/4	48	12	16	7.1	1 1/2	1 1/2	1	37
16-1/2-6	1/2	72	36	24	7.75	1 1/2	1 1/2	1	76
16-1-6	1	72	36	24	7.75	1 1/2	1 1/2	1	76
16-2-6	2	72	36	24	12.6	3 1/4	2	2	128
16-4-8	4	96	48	32	16.6	4 3/4	4 3/4	4-1/2	270
16-5-10	5	120	60	40	20.2	6 1/2	4 3/4	4-1/2	445
16-7-12	7	144	72	48	23.8	8 1/2	6 1/2	7	755

Operation

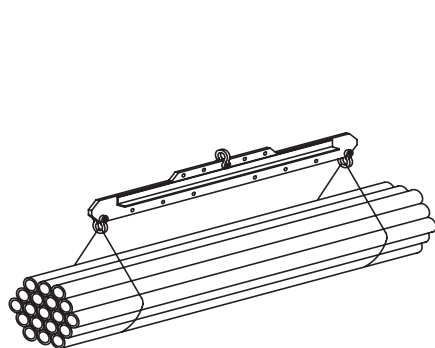

2 Point Lift

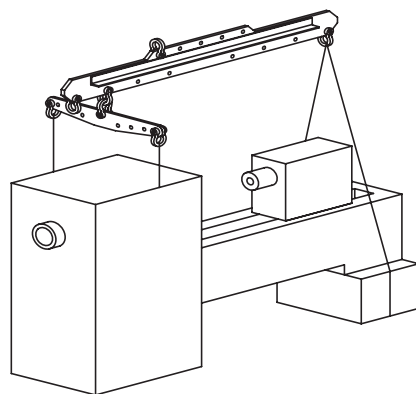

3 Point Lift

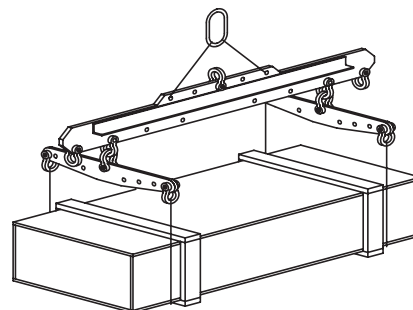

4 Point Lift

Economy Lifting Beams



BLACKTHORN, INC.

• 800-836-6113 FAX 937-836-9395

Model 17 Adjustable Lifting Beam

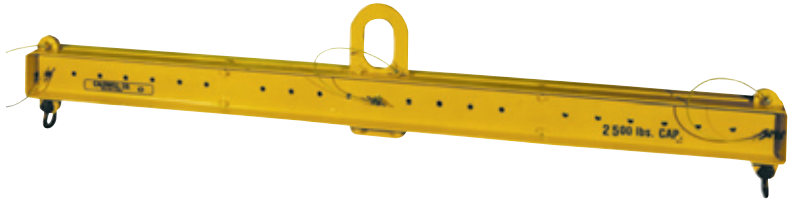

PRODUCT FEATURES:

- ¥ Bail adjusts horizontally for lifting unbalanced loads.
- ¥ Provides clearance in low headroom applications.
- ¥ Spread adjusts in 60 increments along lifting beam.
- ¥ Shackles included.
- ¥ Designed and manufactured to ASME B30.20

PRODUCT OPTIONS:

- ¥ Pair of swivel hooks - Code S

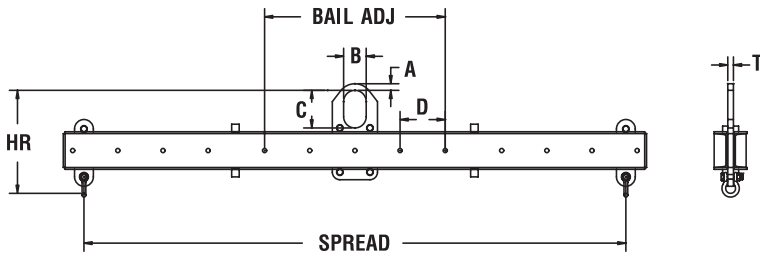

MODEL NO.	RATED CAPACITY (tons)	SPREAD (in.)		BAIL		HEADROOM (in.)	SHACKLE SIZE (tons)	OPTIONAL SWIVEL HOOK (tons)	OTHER DIMENSIONS (in.)				WGT. (lbs.)
		MAX	MIN	RANGE (in.)	ADJ. (in.)				A	B	C	T	
17-1 1/4-6	1-1/4	72	36	24	3	14.7	2	2	1 1/2	3	5	5/8	150
17-2-6	2	72	36	24	3	14.7	2	2	1 1/2	3	5	5/8	155
17-4-8	4	96	54	36	3	19.8	3 1/4	3	2	4	7	3/4	285
17-5-10	5	120	60	36	3	22.4	4 3/4	5	2	4	7	1	475

Operation

BAIL ADJUSTED FOR UNBALANCED LOAD

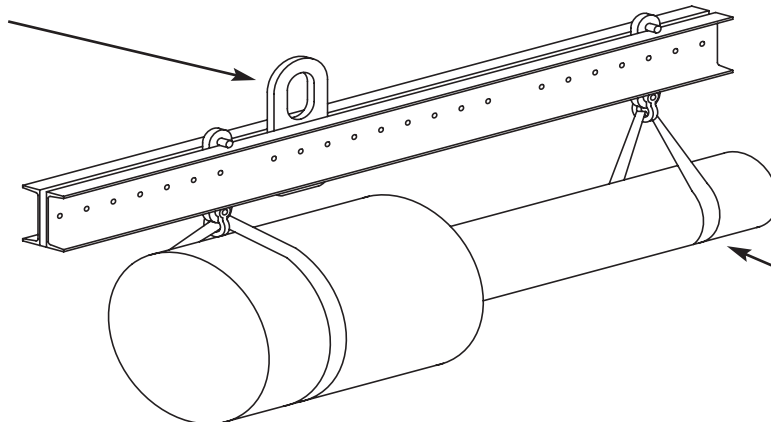

LIFT POINTS ADJUSTED FOR LOAD LENGTH

Economy Lifting Beams



BLACKTHORN, INC.

• 800-836-6113 FAX 937-836-9395

Model 18 Fixed Twin Basket Sling Lifting Beam



PRODUCT FEATURES:

- ¥ Designed to be used with slings in a basket hitch.
- ¥ Provides greatest clearance in low headroom applications.
- ¥ Two sets of bent bar hooks are standard on units with a spread of 6' and greater (one set for 3' and 4').
- ¥ Spread 2 is 1/2 of spread 1.
- ¥ Horns are designed to handle up to a 2" sling eye width.
- ¥ Designed and manufactured to ASME B30.20.

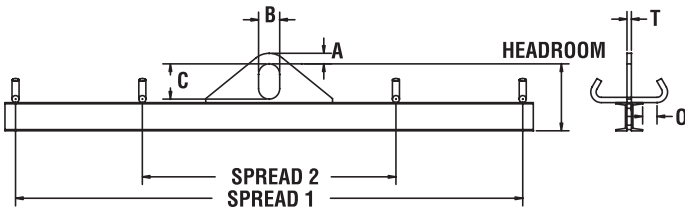

CAPACITY IN TONS	CATALOG # HEADROOM (in.) WEIGHT (lb.)	SPREAD 1 IN FEET						OTHER DIMENSIONS (in.)
		3	4	6	8	10	12	
1/2	CAT.	18-1/2-3	18-1/2-4	18-1/2-6	18-1/2-8	18-1/2-10	18-1/2-12	A=7/8 T=3/4
	H.R.	8-1/2	8-1/2	8-1/2	8-1/2	8-1/2	9-1/2	B=3
	WGT.	40	48	78	95	113	171	C=5
1	CAT.	18-1-3	18-1-4	18-1-6	18-1-8	18-1-10	18-1-12	A=7/8 T=3/4
	H.R.	8-1/2	8-1/2	9-1/2	10-1/2	10-1/2	11-1/2	B=3
	WGT.	40	48	93	136	175	239	C=5
2	CAT.	18-2-3	18-2-4	18-2-6	18-2-8	18-2-10	18-2-12	A=7/8 T=3/4
	H.R.	9-1/2	10-1/2	10-1/2	11-1/2	12-1/2	13-1/2	B=3
	WGT.	52	75	139	169	246	326	C=5
5	CAT.	18-5-3	18-5-4	18-5-6	18-5-8	18-5-10	18-5-12	A=2 T=1/4
	H.R.	13-1/2	14-1/2	15-1/2	16-1/2	17-1/2	19-1/2	B=4
	WGT.	104	135	211	310	423	618	C=7

Operation

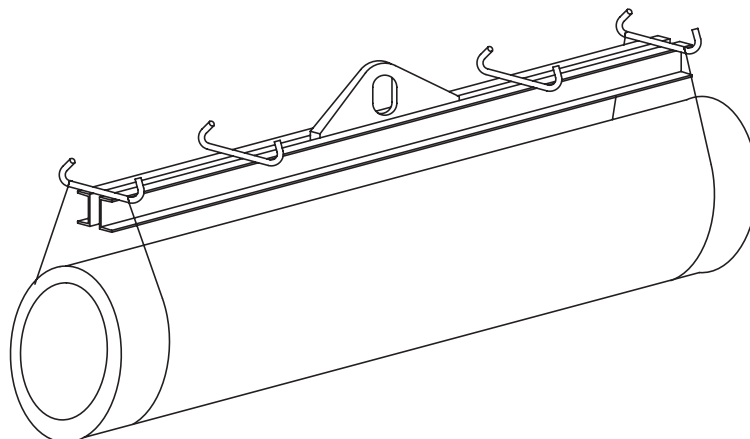

Economy Lifting Beams



BLACKTHORN, INC.

• 800-836-6113 FAX 937-836-9395

Model 19 Fixed Spread



PRODUCT FEATURES:

- ¥ Provides clearance in low headroom applications.
- ¥ Eye hooks with hook latches standard.
- ¥ Cleaner with sealed construction.
- ¥ Fixed spread.
- ¥ Designed and manufactured to ASME B30.20.

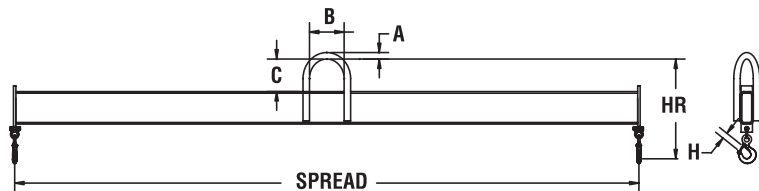

CAPACITY IN TONS	CATALOG # HEAD ROOM (in.) WEIGHT (lbs.)	SPREAD IN FEET				OTHER DIMENSIONS (in.)	
		4	6	8	10		
1/2	Cat.	19-1/2-4	19-1/2-6	19-1/2-8	19-1/2-10	A = 75	H = 89
	H.R.	13 1/4	13 1/4	13 1/4	14 1/4	B = 3	
	Wgt.	39	53	64	95	C = 5	
1	Cat.	19-1-4	19-1-6	19-1-8	19-1-10	A = 1	H = 89
	H.R.	13 1/4	14 1/4	15 1/4	15 1/4	B = 3	
	Wgt.	40	64	100	117	C = 5	
2	Cat.	19-2-4	19-2-6	19-2-8	19-2-10	A = 1	H = 1
	H.R.	16 3/4	17 3/4	19 3/4	19 3/4	B = 3	
	Wgt.	57	89	114	138	C = 5	
3	Cat.	19-3-4	19-3-6	19-3-8	19-3-10	A = 1/2	H = 1
	H.R.	21	23	23	23	B = 4	
	Wgt.	78	138	173	284	C = 7	

Operation

